

ITALERI

# Tornado ECR

No 2517 model kit  
 modèle réduit



## Caratteristiche del modello

- Più di 350 pezzi
- Dettagli in fotoincisione
- Motore RB.199 estraibile con carrello speciale di supporto
- Alette e flaps retratti o aperte
- Alettoni mobili
- Radome apribile con radar dettagliati all'interno

**NEW PARTS**

- Invertitori di spinta aperti o chiusi
- Freni ad aria aperti o chiusi
- Pneumatici in gomma
- Ali e piloni a geometria variabile
- Copertura in gomma nel punto di rientro delle ali
- Foglio istruzioni a colori
- Super foglio decals per 3 versioni

**1:32**  
 scalascale

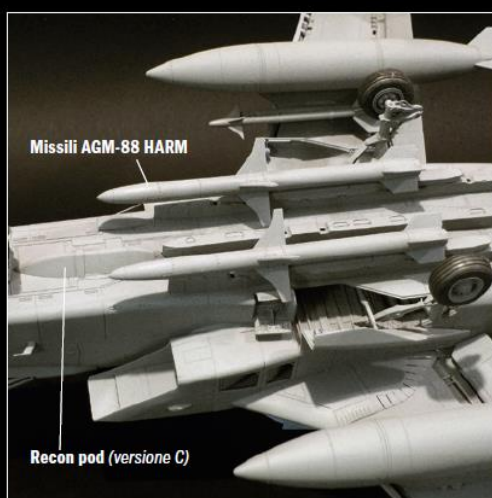
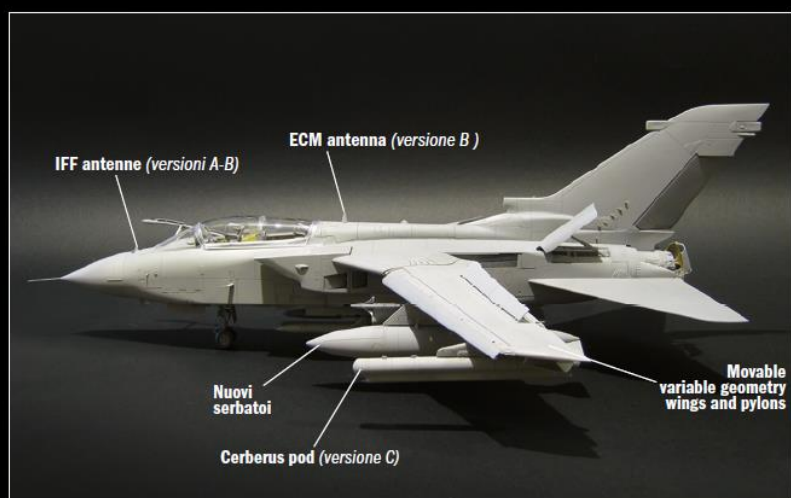

## Profilo Storico Modellistico

Il progetto del Tornado è nato dalla collaborazione di Italia, Germania e Regno Unito per la realizzazione di un aereo da combattimento multiruolo dalle alte prestazioni di volo. Venne così sviluppato un aereo bimotore, con configurazione biposto ed ali a geometria variabile per meglio rispondere al suo ruolo principale: caccia bombardiere supersonico a bassa quota in grado di "seguire" il profilo del terreno. Il Tornado IDS (Interdictor/strike), ideale per le missioni di attacco, è stato il primo ad essere impiegato dai reparti operativi di volo dei tre Paesi che svilupparono il progetto. Dal progetto originario venne realizzata anche la versione ECR (Electronic Combat/ Reconnaissance), impiegata dall'Aeronautica Militare Italiana e dalla Luftwaffe tedesca, equipaggiata per svolgere missioni di soppressione delle difese aeree nemiche (SEAD), guerra elettronica e ricognizione avanzata.

**ITALERI**



Radome apribile  
 con radar dettagliati all'interno

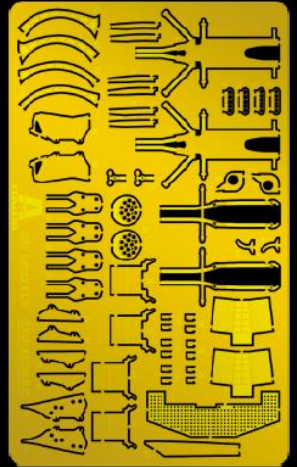
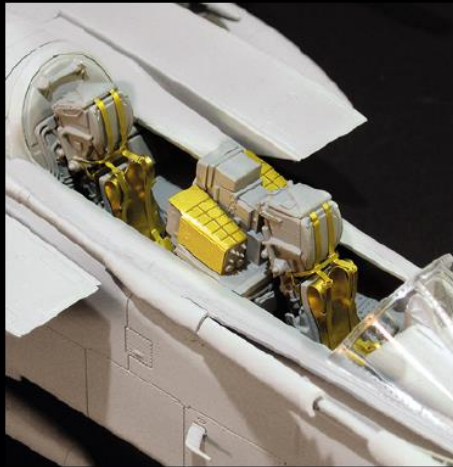

Freni ad aria  
 aperti o chiusi



pneumatici in gomma FLIR pod



Motore RB.199 estraibile  
 con carrello speciale  
 di supporto



Copertura in gomma nel punto  
 di rientro delle ali



Alette e flaps retratti o aperte  
 Alettoni mobili, ali e piloni a geometria variabile



A. (Cover) TORNADO EA-200B ECR, Aeronautica Militare, 6o Stormo,  
 155mo Gruppo, Ghedi Montichiari Air Base, 2019.



B. TORNADO EA-200B ECR, Aeronautica Militare, 50° Stormo,  
 operation "Unified Protectors", Trapani-Birgi Air Base, March 2011.



C. (Cover) TORNADO ECR, Luftwaffe, T  
 aktisches Luftwaffengeschwader 51,  
 Royal International Air Tattoo, Fairford AB, UK, 2017.

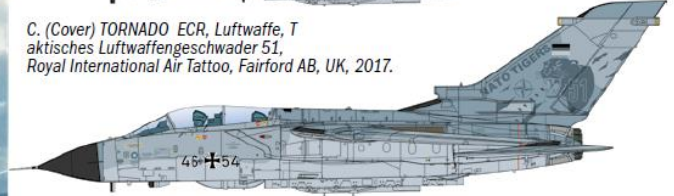

Color instruction sheet and Super decals sheet for 3 versions

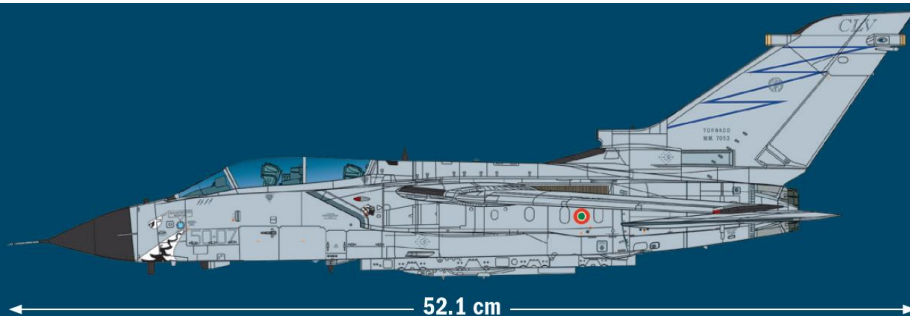

ITALERI

Battle Set

**Montecassino Abbey 1944**  
 Breaking the Gustav line

No 6198 model kit modèlle réduit

1:72 scale



Content



Montecassino Abbey  
 "Wreckable" MDF laser cut



M4A2 Sherman III

Fast assembly model

Polish infantry



50 figures

German Paratroopers



32 figures



Sturmgeschütz III

Fast assembly model



Battle Set

**Montecassino Abbey 1944**  
 Breaking the Gustav line

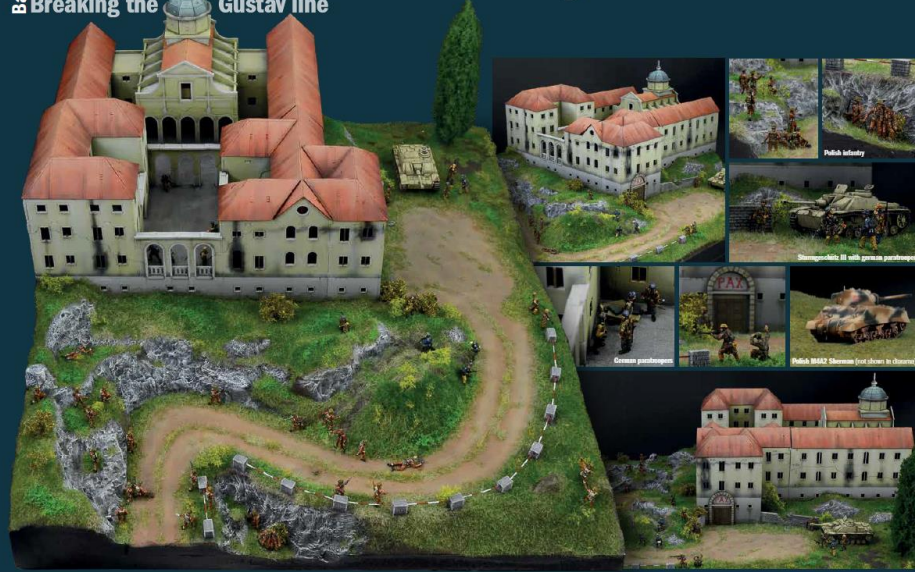

Content



M4A2 Sherman III

Fast assembly model



Polish infantry

32 figures



German Paratroopers

32 figures



Sturmgeschütz III

Fast assembly model



Montecassino Abbey

"Wreckable" MDF laser cut



Intact layout



Wrecked layout



IT6198

Montecassino Abbey 1944 Breaking the Gustav line **BATTLE SET**

1/72



IT3621

FIAT 131 Abarth  
 1977 Sanremo Rally winner

1/24



IT1459

Jaguar GR.1 / GR.3 R.A.F.  
 include decal per 5 versioni

1/72

**ITALERI** articoli nuovamente disponibili



AERONAUTICA  
MILITARE

IT1360

**CANT Z 506 AIRONE**  
 scatola con ologramma AMI

1/72



IT2764

**CESSNA 172 SKYHAWK**  
 Landing on Red Square (1987)

1/48

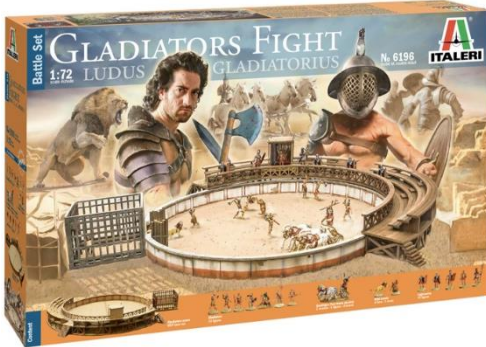

IT6196

**GLADIATORS FIGHT - BATTLE SET**

1/72



IT6549

**STEYR RSO/01 with GERMAN SOLDIERS**

1/35



IT6580

**M7 Priest**  
 nuovi cingoli in gomma incollabili

1/35



IT6524

**LCVP with U.S. INFANTRY**  
 28 FIGURE MULTI-POSA U.S. INFANTRY

1/35



IT6529

**M4A3E8 SHERMAN "FURY"**

1/35

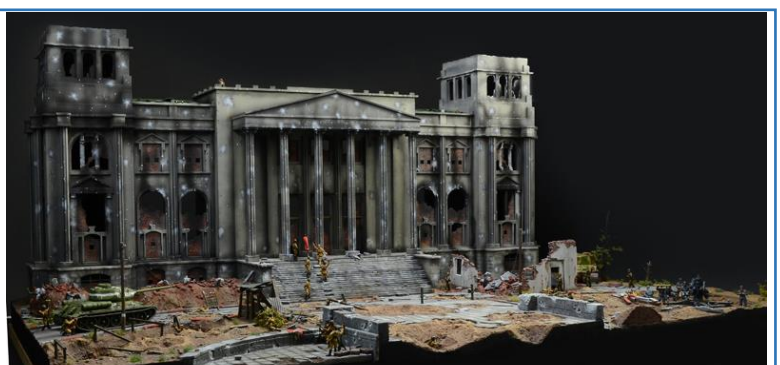
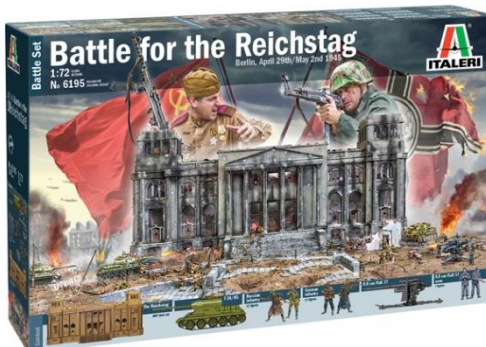

IT6195

**Battle for the Reichstag 1945 - BATTLE SET**

1/72

**DRAGON** Limited Edition



DR6007 GERMAN SUPER TANK 'MAUS' 1/35



DR6085 GERMAN RAILWAY FLATBED Typ Ommr (2 AXLE) w/MG CREW 1/35



DR6484 Gruppe Fehrmann Tiger I (Smart Kit)  
 Magic tracks will replace DS tracks

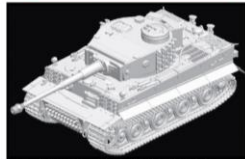

• Composite mixture of Early- and Late-Production Tigers realistically mimic the real vehicle  
 • Spare-track arrangement unique to Gruppe Fehrmann

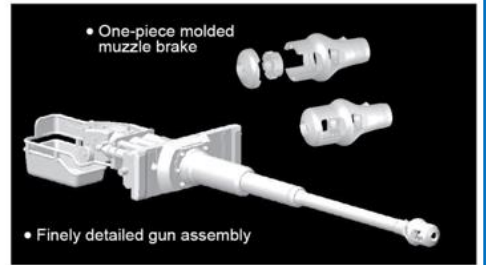

- One-piece molded muzzle brake
- Finely detailed gun assembly

1/35



DR6258 PANZERJÄGER I 4.7cm PaK(t) EARLY Magic tracks 1/35



DR6259 15cm s.IG.33(Sf) auf Pz.Kpfw.I Ausf.B Magic tracks 1/35



DR6577 FLAKPANZER I Magic tracks 1/35



DR6290 Pz.Kpfw.38(t) Ausf.G w/INTERIOR Magic tracks 1/35



DR6464 MARDER III Ausf.M INITIAL PRODUCTION Magic tracks 1/35

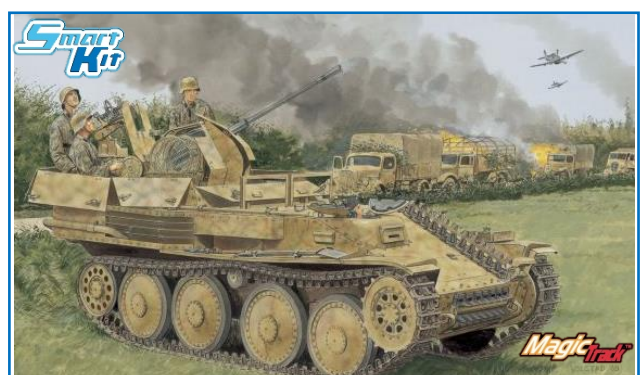

DR6590 FlaK 38(t) Ausf.M LATE PRODUCTION Magic tracks 1/35

**DRAGON Limited Edition**



**DR6624** Tiger I Mid Production w/Zimmerit s.Pz.Abt.506 Eastern Front 1944 **1/35**



**DR6684** GERMAN RSO/3 w/5cm PaK 38 (SMART KIT) **1/35**

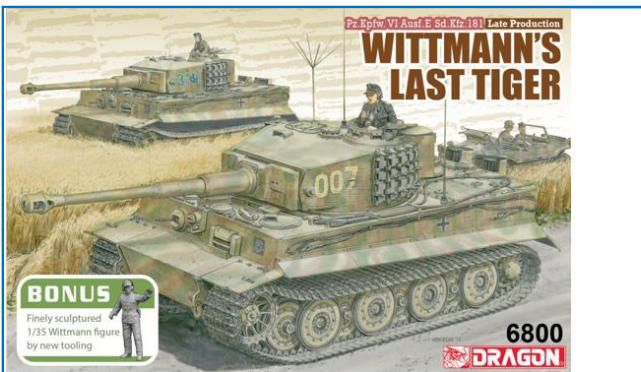

**DR6800** "Wittmann's Last Tiger" Pz.Kpfw.VI Tiger I Late Production w/Zimmerit  
 Magic tracks will replace the DS

**1/35**

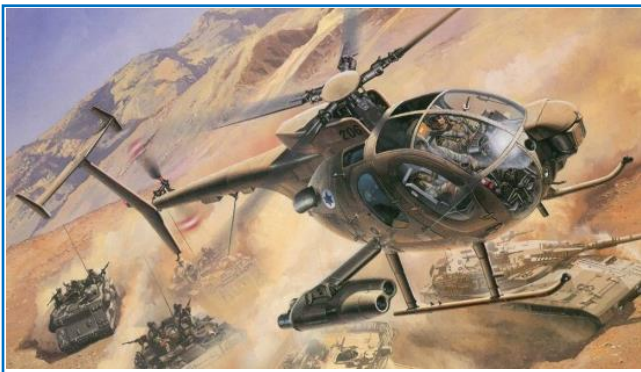
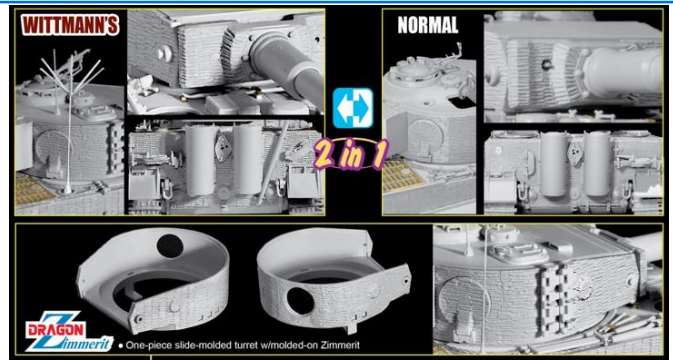

**DR3525** MD500 DEFENDER **1/35**



**DR3580** MIM-23 HAWK M192 ANTI-AIRCRAFT MISSILE LAUNCHER **1/35**



**DR3544** M48A3 MOD.B (SMART KIT) **1/35**



**DR3557** M270A1 MLRS **1/35**



**DR3559** M48A1 (SMART KIT) **1/35**

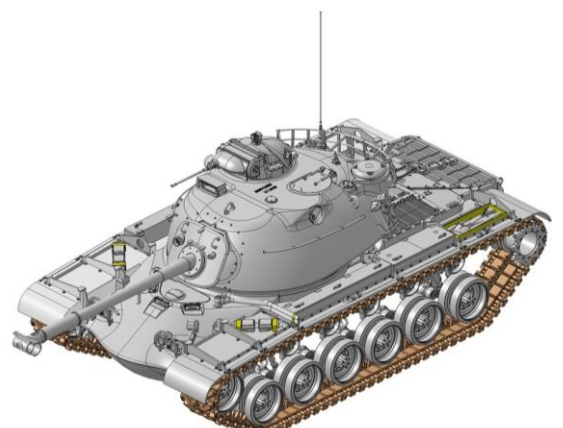

**DRAGON** Limited Edition



DR6580

**GERMAN INFANTRY  
 BARBAROSSA 1941**

1/35



DR6116

**PANZERMEYER, LSSAH  
 DIVISION (MARIUPOL 1941)**

1/35



DR6744

**SOVIET INFANTRY WINTER 1941**

1/35



DR6105

**WEHRMACHT INFANTRY  
 (BARBAROSSA 1941)**

1/35



DR6651

**15cm s.I.G.33(Sf) auf Pz.Kpfw.I  
 Ausf.B Magic tracks**

1/35



DR6157

**2nd Fallschirmjäger Division  
 (Kirovograd, winter 1942/43)**

1/35



DR6145

**FALLSCHIRMJÄGER  
 BATTALION 500 (DRVAR 1944)**

1/35



DR6309

**VERFÜGUNGSTRUPPE  
 (FRANCE 1940)**

1/35



DR6552

**BRITISH EXPEDITIONARY  
 FORCE, FRANCE 1940**

1/35

**DRAGON Limited Edition**



**1/6 DAK KÜBELWAGEN TYPE 82**



•Canvas roof provided



•Adjustable windshield made from clear plastic



•Doors can be opened or closed with movable door handles



•Unique balloon tires



•Realistic steering system - steering wheel linked to front wheels



•Shovel can be removed from vehicle for diorama use



DR75021

DAK Kubelwagen Type 82

1/6

• Accurate Sd.Kfz.251/1 Ausf.D mit 28/32cm Wurfrahmen 40 rendered in 1/35 scale

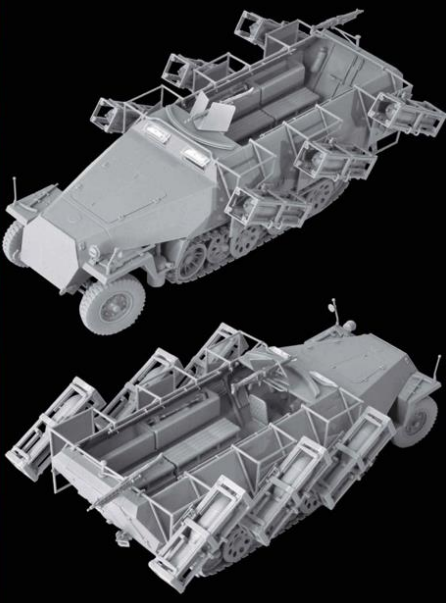

**Sd.Kfz.251/1 Ausf.D mit 28/32cm WURFRAHMEN 40**  
 1:35 '39-'45 SERIES



DR6861

Sd.Kfz.251 Ausf.D with 28/32cm Wurfrahmen 40 (2 in 1)

1/35



**DRAGON Limited Edition**

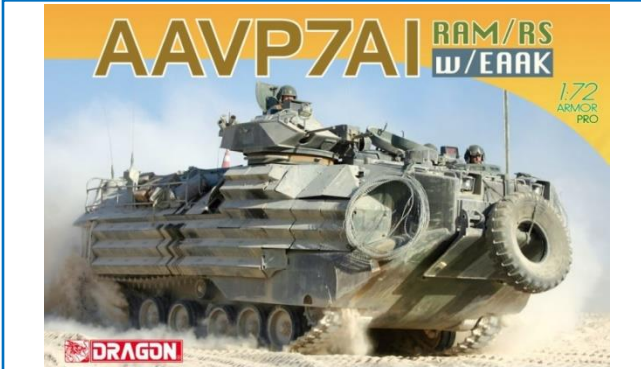

**DR7233**    **AAVP7A-1 RAM/RS w/EAAK**    **1/72**

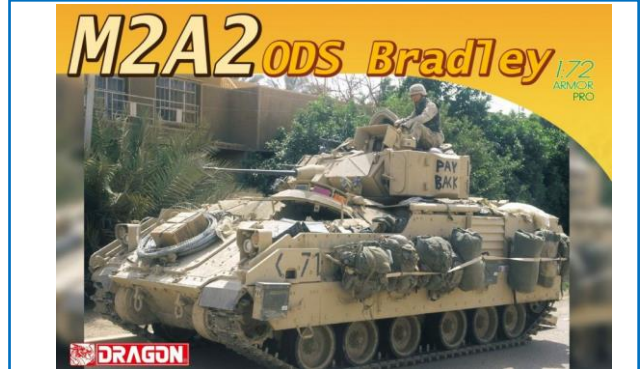

**DR7331**    **M2A2 ODS Bradley**    **1/72**



**DR7701**    **SAS Bushmaster**  
*Nuove parti*

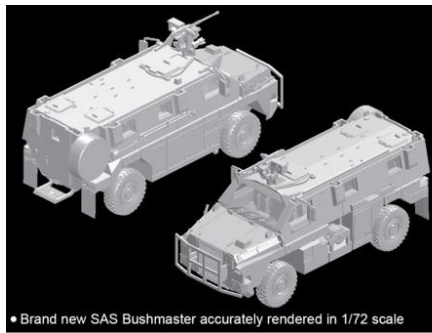

• Brand new SAS Bushmaster accurately rendered in 1/72 scale

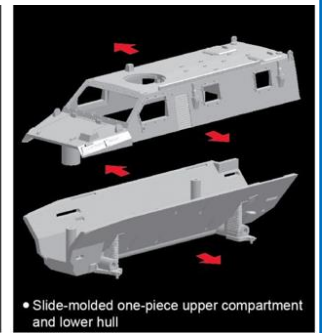

• Slide-molded one-piece upper compartment and lower hull

**1/72**



**DR7413**    **M3A2 ODS Bradley**    **1/72**



**DR7682**    **PLA ZBL-09 IFV**    **1/72**



**DR7368**    **Gruppe Fehrman Tiger I**



• Spare-track arrangement unique to Gruppe Fehrman

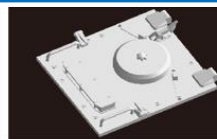

• Authentically reproduced access hatches for HL 230 engine



• Detachable spare tracks can be hung on turret sides

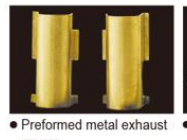

• Preformed metal exhaust covers

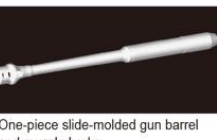

• One-piece slide-molded gun barrel and muzzle brake

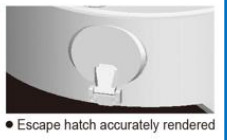

• Escape hatch accurately rendered

**1/72**



**DR7683**    **PLA ZTL-11 Assault Gun**  
*Include 1 mezzo militare*    **1/72**



**DR7684**    **PLA ZSL-10 APC**    **1/72**